

Lifting station Minilift S KTP 300, resistant, Floor slab, black

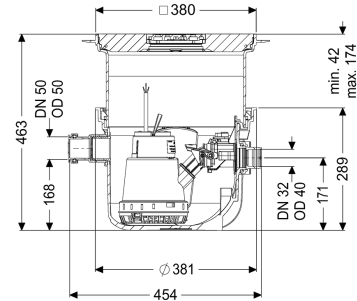

Article information

Item no.: 280570SC
 GTIN: 4026092093511
 Price group: 20

Advantages

- Space-saving installation in the floor slab with integrated drainage function
- System ready to plug in
- Easy tool-free maintenance

Description

The ready to plug in small lifting station for faecal-free wastewater is suitable for wastewater drainage of individual sanitary appliances. The submersible pump with float switch can be removed easily with the help of one-handed closures. The collection tank made of polymer (PE) has an open pump tank and is resistant to aggressive wastewater. The system for installation in the floor slab is preassembled for final installation on site.

Variant

Type of system:
 Resistant:

Single unit
 Resistant to saline media, wastewater from water softening systems and wastewater containing condensate from heating systems

Pump control:
 Backflow preventer:

Float switch
 integrated

General characteristics

Colour:
 Standard:
 Type of wastewater:
 Installation situation:
 Delivery state:

grey
 EN 12050-2
 without sewage
 floor slab installation
 Installation-ready (connection parts must be connected on site)

ATEX:

no

Dimensions

Net weight:	10,8 kg
Gross weight:	11,8 kg
Installation depth:	330 - 460 mm
Type of height adjustability:	vertically adjustable upper section
Length:	460 mm
Width:	380 mm
Packaging dimension:	length
Packaging dimension:	width
Packaging dimension:	height

Tank/drain body

Pressure pipe connection (DN):	32
Pressure pipe connection (OD):	40 mm
Inlet nominal size (DN):	50 mm
Pumping volume:	7 l
Tank volume:	26 l

Coverage features

Type of cover:	Cover plate with slotted cover
Cover material:	Polymer
Colour of cover:	silver grey
Width of cover:	366 mm
Length of cover:	366 mm
Locking:	Lock & Lift
Load class:	K 3 (EN 1253-1)

Pumping device

Pump:	KTP 300 resistant
Number of pumps:	1
Weight, pump:	4 kg
Connection type:	Schuko (earthed contact) 2-pin
Rated current:	1,6 A
Protection class:	I
Insulation class:	F
Protection class (pump):	IP 68 (3m)
Temperature monitoring:	integrated
Max. temperature (permanent) of conveyed material:	40 °C
Hot water resistance for a short time (2 min):	80 °C
Max. pumping capacity:	8 m ³ /h
Max. pumping height:	6 m
Speed:	2800 U/min
Power P1:	0,34 kW
Power P2:	0,21 kW
Operating mode:	S1
Type of fuse required (electrical protection):	C 16 A
Type of pump connection cable:	H07RN-F 3G 1.5 mm ²
Impeller type:	Multi-vane impeller
Free passage:	10 mm

Length of mains cable for pump:	5 m
Control	
Motor protection switch:	yes
Level measurement instrument:	Float switch
Type of level measurement:	mechanical
Mains frequency:	50 Hz
Operating voltage:	230 V
Connection type:	Schuko (earthed contact) 2-pin
Type of fuse required (electrical protection):	C 16 A