

## Pumping station Aquapump XXL Duo, GTF 5200-S1

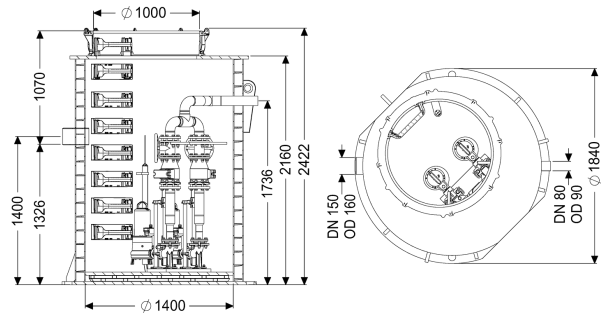

### Article information

Item no.: 8743044  
 GTIN: 4026092078129  
 Price group: 60

### Advantages

- Maximum safety
- Flexible installation
- Also handles large quantities of wastewater without sewage

### Description

The pumping station is equipped with one or two submersible pumps and a backflow preventer. The collection tank made of permanently resistant polymer (PE) has an open pump tank with universal connection options. Quick-release closures enable the integrated components to be removed easily. The KESSEL modular system provides different engineering chamber options as accessories for the further layout. Stainless steel pump removal chains available as accessory for each installation depth - Article number:

680528 = Length 2 m 680529 = Length 3 m  
 680530 = Length 4 m 680531 = Length 5 m

Variant

Note on installation depth:

Type of system:

Shut-off valve:

Passage seal for conduit pipe (DN):

Access steps:

Passage seal for ventilation pipe (DN):

Installation:

Pump control:

Backflow preventer:

Pressure pipe connection:

in combination with a chamber module  
 duo pump

Shut-off valve made of cast iron

100

yes

100

Wet installation

Control unit

integrated

horizontal

Chamber system:	Twin walled re-enforced pipe chamber
General characteristics	
Colour:	black
Standard:	EN 12050-2 as well as EN 12050-1 (without ATEX requirements)
Type of wastewater:	for wastewater with or without sewage (in installation situations without ATEX requirements)
Installation situation:	underground installation
Delivery state:	Pre-mounted for final assembly on site (pumps and sensor system must be fitted on site and control unit must be connected)
System type:	Duo
ATEX:	no
Dimensions	
Net weight:	710 kg
Gross weight:	760 kg
Groundwater resistant from lower edge of base section:	3000 mm
Length:	1880 mm
Width:	1880 mm
Height:	2440 mm
Packaging dimension:	length
Packaging dimension:	width
Packaging dimension:	height
Tank/drain body	
Pressure pipe connection (DN):	80
Pressure pipe connection (OD):	90 mm
Distance from centre of outlet pipe to tank bottom:	1735 mm
Distance pipe bottom inlet to tank bottom:	1320 mm
Distance from centre of inlet pipe to tank bottom:	1400 mm
Distance from inlet pipe invert to top of tank:	1090 mm
Inlet nominal size (OD):	160 mm
Inlet nominal size (DN):	150 mm
Number of inlets:	1
Clear width of tank (LW):	1600 mm
Clear width of entry (LW):	1000 mm
Pumping volume:	880 l
Pumping device	
Pump:	GTF 5200
Number of pumps:	2
Weight, pump:	56 kg
Connection type:	Direct connection
Rated current:	8,7 A
Protection class:	I

Insulation class:	H
Cos phi - power factor:	0,85
Protection class (pump):	IP 68 (20m)
Temperature monitoring:	integrated
Max. temperature (permanent) of conveyed material:	40 °C
Max. pumping capacity:	52,8 m <sup>3</sup> /h
Max. pumping height:	21 m
Speed:	2835 U/min
Power P1:	5,2 kW
Power P2:	4,4 kW
Operating mode:	S1
Type of pump connection cable:	H07RN8-F PLU 10G 1.5 mm <sup>2</sup>
Impeller type:	Multi-vane impeller
Length of mains cable for pump:	10 m
Control	
Control unit:	Comfort Plus
Motor protection switch:	yes
Alarm sensor:	Level sensor
Level measurement instrument:	Level sensor
Type of level measurement:	hydrostatic
Protection class control unit:	IP 54
Mains frequency:	50 Hz
Operating voltage:	400 V
Connection type:	Direct connection
Potential-free contact:	yes
GSM interface:	yes
USB interface:	yes
Log book function:	yes
Multi-line display:	yes
Battery buffering:	yes
Self-diagnosis system (SDS):	yes